



Today, hundreds of different gating systems and overflow wells can be assessed overnight by automatic optimization. The computer lists all variants, simulates the casting process and automatically finds the optimum variant. (Photo: MAGMA)

Automatic computerized optimization in die casting processes

The simulation of die filling and solidification processes was first applied in foundries more than 20 years ago. Although casting simulation is still a young technology, it has gained wide acceptance. More than 150 foundries in Germany use simulation programs. In addition to larger foundries and direct automotive suppliers, simulation

has become an established practice also in SME foundries. They use simulation mainly as a tool for testing the quality of castings for new or modified equipment [1].

Due to the multitude of factors affecting the quality of castings and the complex interactions of physics, metallurgy and casting geometry, empirical knowledge was the principal resource on which “optimized manufacturing engineering” relied. Foundry simulation can quantify experience and therefore only test a “state”, whereas the conclusions

from the calculations and improvements require the hands of an expert. Continuous improvement and optimization is a succession of trials and errors, both in reality and in simulation.

In recent years, response time of simulation software has improved and now integrates parallel process computers. The computing time needed for one variant of the casting process to be optimized can thus be completed within a few minutes. Combining simulation software with an optimization program makes is

Dr.-Ing. Ingo Hahn, Dr.-Ing. Götz Hartmann,
Magma Gießereitechnologie GmbH, Aachen, Germany
www.magma-soft.de

possible to automatically analyze calculated variants with regard to the defined target criteria (e.g. low porosity and low rate of returns), to create new variants and to analyze them in the same way. The vision of automatic computer-assisted solution-finding for casting problems has become reality. A number of examples can be found, first and foremost, in gravity casting. Here, especially the optimization of riser technology should be mentioned, [2], but also the geometry of runners and gates is increasingly designed by this technology [2, 3, 4].

This paper looks at examples of the application of this next generation casting process simulation in pressure die casting.

Process development for pressure die casting

A major aspect of process development for pressure die casting is the design of dies for die filling and heating.

Foundry experts can spontaneously name a long list of optimization targets that they usually try to reach all at the same time:

- to avoid delamination of the melt in the runner as well as turbulences and gas porosities in the casting;
- to avoid oxides and inclusions;
- to achieve simultaneous and uniform filling of cavities in multiple dies, depending on their location, the pouring system, and the casting parameters;
- to optimize the gate cross sections for efficient feeding, including thin-walled sections;
- to dimension and position gates and to design die heating to avoid shrinkage porosity;
- to minimize the runner volume to reduce returns;
- to avoid cold laps by improving the main flow control in the casting.

Figure 1

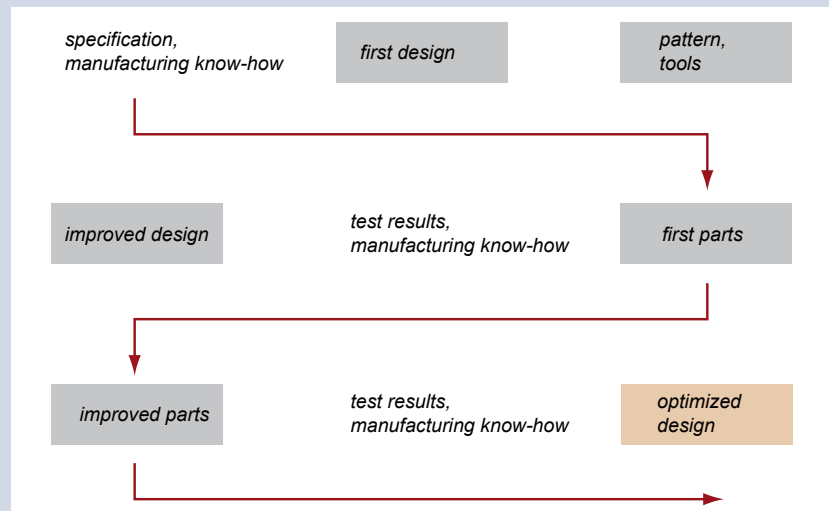

To optimize casting by the conventional approach, a first method must be designed based on experience, the casting inspected and modified systematically if problems are encountered. This process is repeated until a satisfactory result is obtained.

Figure 2

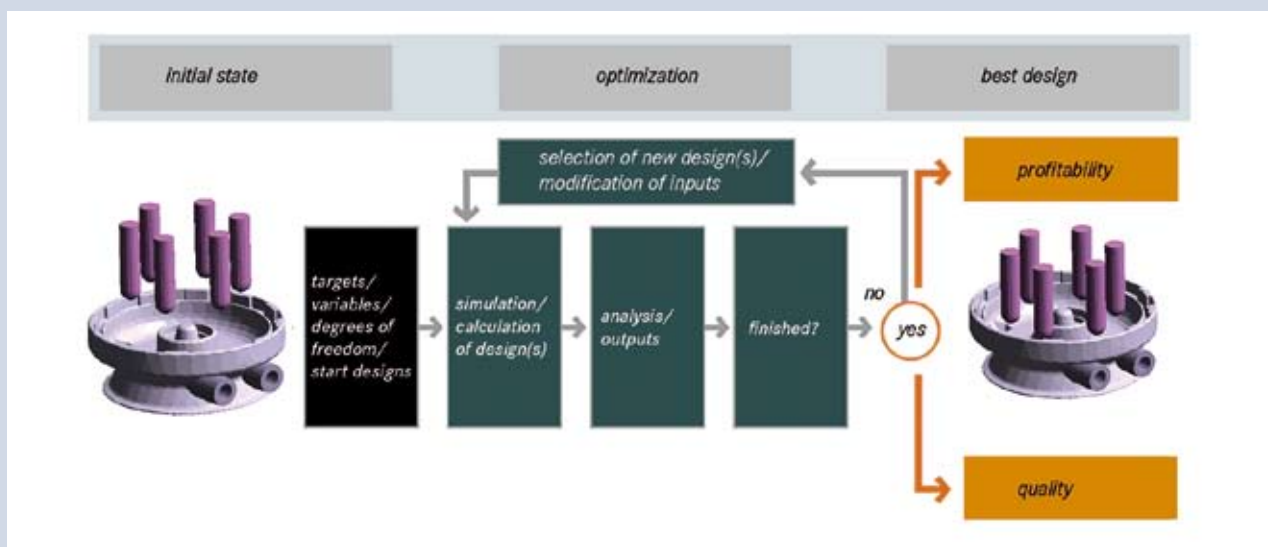

Optimization with MAGMAfrontier. Based on a choice of start designs with appropriate degrees of freedom and manufacturing restrictions, the optimization algorithm automatically carries out a simultaneous analysis of several objectives and finds optimized production parameters, such as the location of coolers.

Figure 3

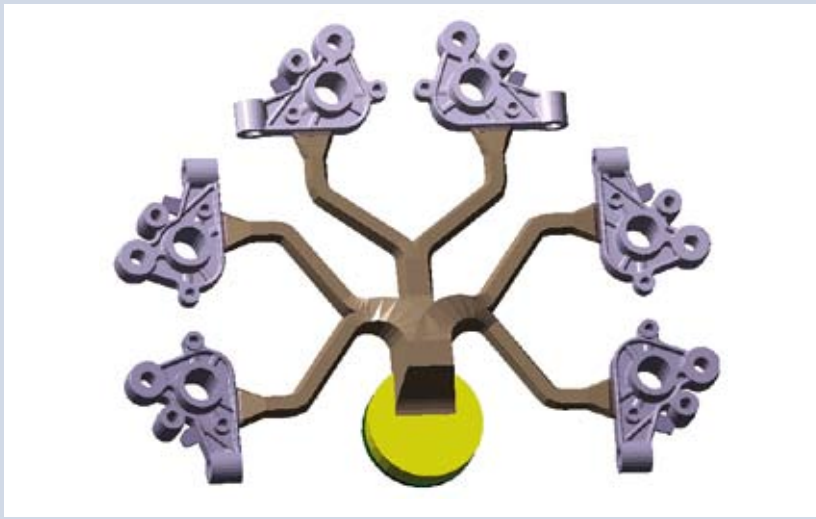

Runner CAD of a six-cavity die. The layout in the figure is obtained as a result of arranging the cavities on as little space as possible.

Figure 4



Three different variants of a running system. The parametric geometry supports variations of the cross sections of runner and gates at any required position.

Figure 5

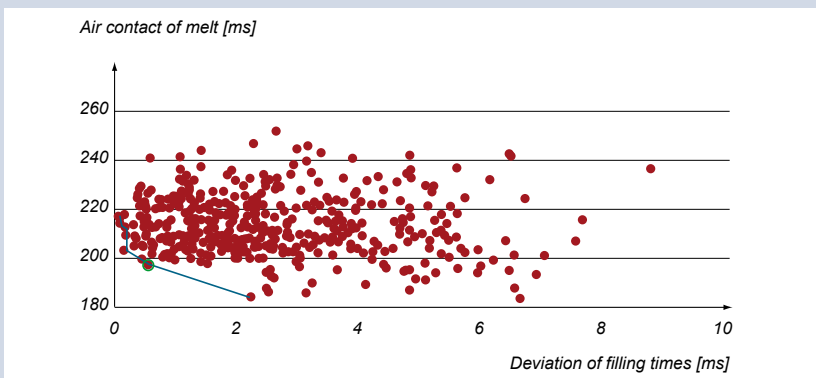

Duration of air contact of the melt in the die cavities and deviation of filling times for the variants calculated by the optimization algorithm

Additionally, there is the die life time, which is affected by the flow rates in the gate and by the temperature changes in the pouring cycle.

The shapes of the running system and of the gate are important parameters in pressure die casting. The flow rates in the gate have a critical impact on the die filling process. The defined shot curves of the casting machine must be adapted to the running system in the permitted range.

Optimizing the casting process by “one-dimensional search”

Each foundry has a number of processes that are subject to constant improvement. This is driven by the necessity to improve the quality of castings or to cut the costs of production. Basically, a simple optimization method is applied: the “one-dimensional search” that after a number of successive trials, tests and improvements finally should produce an acceptable result, although it is not known whether this is the genuine absolute optimum. Therefore, runner optimization means that a first variant of the casting technique is designed based on experience, then the casting is inspected and if a problem occurs, the technique is modified (again empirically). This process is repeated until the quality of the casting and/or the cost efficiency of the process is acceptable (Figure 1).

Typical of the “one-dimensional search” is the small number of trials and the risk of ending up in a deadlock. There are numerous examples from foundries to prove this: Quite often, though, foundries found a surprising solution to their problems after a radical reorientation. The “one-dimensional search” is a method of optimization that fits human ways of thinking and acting. It can work systematically and quickly because experience and power of comprehension enable man to obtain a relative optimum after only a few trials.

Figure 6

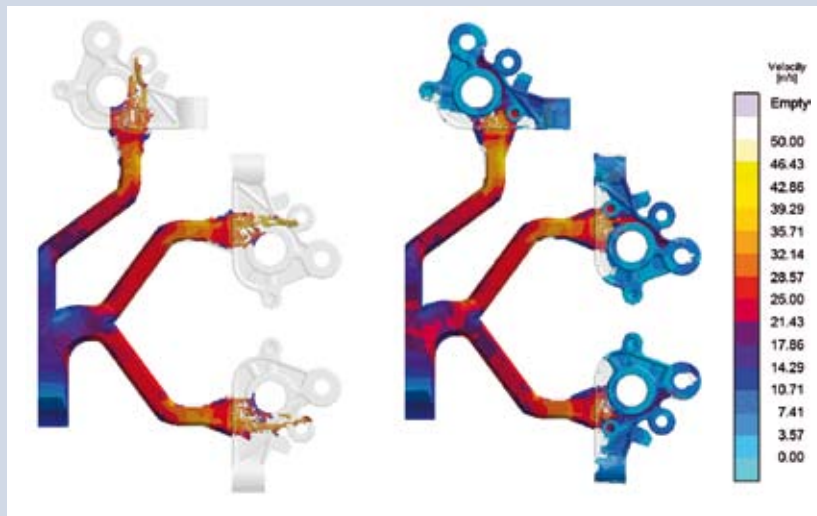

Flow rates in the die at 970 ms (left) and 986 ms (right) after start of plunger movement

In foundry practice, the effectiveness of this optimization approach has substantially improved in recent years: Today, trials are often not carried out in reality using pattern, die and casted prototype, but virtually by means of simulating the casting process. At the same time, the requirements on productivity and robustness of the production process of high-quality die

cast parts increase constantly. Financial necessities require accurate planning of the die concept and the manufacturing process. With the increasing complexity of the die castings, the application of experiences to new projects becomes ever more complicated and therefore questionable. There is an urgent necessity to eliminate the trial-and-error factor for the user.

Automatic computerized optimization

Automatic computerized optimization represents a new approach to solve difficulties in the manufacturing process. MAGMASOFT simulation calculations with varying process parameters and die layouts are used as an experimental ground. For this, the simulation program was integrated into an optimization loop that runs without user interaction after optimization targets and degrees of freedom were defined. Several objectives, even contradictory objectives, can be pursued at the same time (e.g. casting quality, productivity, material input). To have a positive impact on the optimization targets, manufacturing variables (e.g. casting conditions, materials, die temperature, shot curves, spray conditions) and geometries (e.g. runner design, gate dimensioning, position and dimension of cooling channels) can be varied. Manufacturing restrictions (e.g. cycle times, die concept) can be taken into account (Figure 2).

The MAGMAfrontier optimization tool is based on genetic algorithms. The first generation of variants is defined as DOE (design of experiments) –

Figure 7

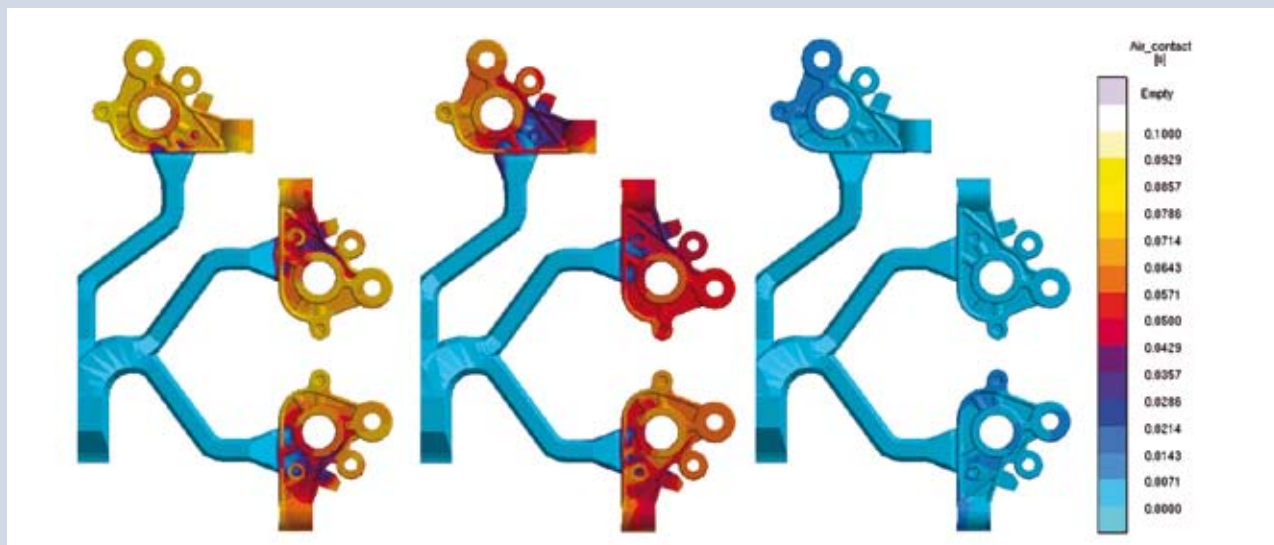

Air contact of the poured melt (a) before optimization, (b) after geometrical optimization, and (c) after optimization of the shot curve. The duration of air contact during die cavity filling is used as the measure of intensity regarding the tendency to form oxide.

Figure 8

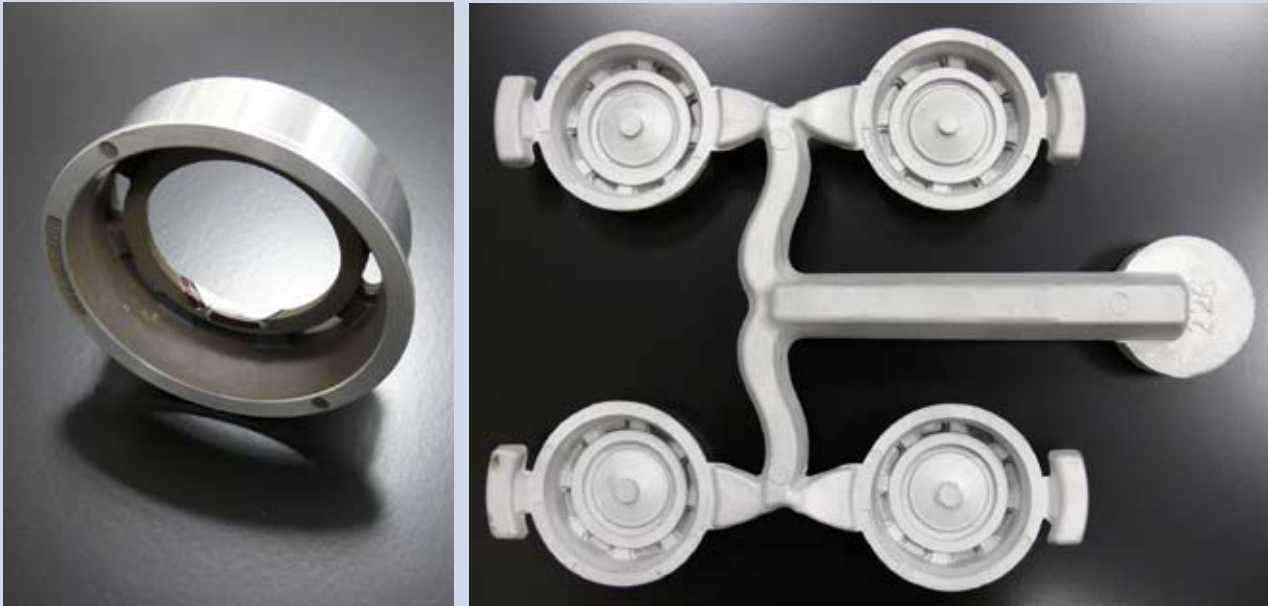

Cast piston rings; the area at the ring circumference is machined and must be absolutely free of pores.

using the example of statistical experimental design – from the mostly very large number of possible variations. Several generations are then processed. According to the laws of genetics, positive characteristics will “survive”, such as few air pockets, reduced shrinkage porosity or increased yield. The best possible compromises between in-

dividual objectives are found in this way. The quantitative information on the impact of the varied process conditions obtained during optimization can also be used for sensitivity studies. Hence, the foundry expert obtains far more information from the optimized results than only on the part in question. The “trial and error” method is

now transferred to the computer. The next generation of casting process simulation makes proposals for optimum parameter combinations or the best possible layout. This will be explained with the following examples covering important process development areas for die casting.

Homogenizing die filling with minimized oxide formation

Most small castings are produced in multiple-cavity dies. To produce products of uniform quality and to allow smooth filling of the die, the cavities should all be filled at the same time and local flow peaks should be avoided. In this first example, six castings are poured simultaneously (Figure 3).

Normally, the courses of the cross sections of the six runners are designed by the engineer based on experience and proven tables. In our case, this is provided by the optimization program. A parametric three-dimensional model of the geometry is introduced in MAGMASOFT for this purpose. Figure 4 shows some possible designs of the runner system. Taking advantage of the available symmetry,

Figure 9



Three different variants of the geometry of gates and overflow tabs. The angle around the casting and the extension of the overflow tabs are varied.

Figure 10



Air distribution in the casting after filling before (left) and after (right) optimization

Figure 11



Front view of the flange. The bolt-on pieces are critical to shrinkage porosity.

the calculation of always half the die plate is sufficient for the simulation.

The filling time for each die cavity is known after the simulation. This is the time span from when the plunger begins to move until the complete filling of the cavity. The target function for the optimization program is to make the deviations between the filling times of the die cavities as small as possible by selecting certain runner cross sections.

Apart from the homogeneous filling process of all cavities, oxides in the castings should also be avoided in this example. As a result of the simulated die filling, the intensity with which the melt is exposed to air can also be analyzed as local distribution

across the filled die cavity. The on this basis calculated reduction of oxide formation in the cavities was defined as the second target function of the optimization program.

Figure 5 illustrates the air contact in the die cavities and the deviation of filling times for 486 calculated variants. Each point represents one variant calculated by the optimization algorithm. Variants rated “good” are located in the left lower range of the diagram, where homogeneous filling of cavities with the shortest air contact was found. The blue line in the diagram marks the best variants suggested by the target functions – the optimum, finally, is obtained by the engineer weighting the two objectives. The comparative analysis of the variants of an optimization run provides only qualitative data; a detailed analysis of the simulation results concerning the target variants is unavoidable.

The “best compromise” between both objectives is represented by the green variant in the diagram. Figure 6 illustrates the filling of the die cavity for the appropriate running system at two different times. The cavities are filled simultaneously – this is an example of a genuine homogeneous filling. Initially, the detailed analysis of oxidation failed to produce a sat-

isfactory result, as it can be seen in Figure 7. The scatter diagram shows a qualitative reduction of air contact due to the variation of the geometry of the running system. However, the improvement obtained with this variant is not enough to talk about an absolutely satisfactory result. In a second optimization run the shot curve was varied in addition to the geometry of the runner cross sections. The additional degrees of freedom available to the optimization program in this case were the switchover point and the speed of the plunger in the second phase of die cavity filling. The improvement regarding the tendency for the formation of oxide obtained in 620 simulated variants is shown in Figure 7. No further improvements regarding the deviations of the filling times in comparison with the purely geometrical optimization were possible.

The optimization of the shot curve may appear to be slightly academic considering the practical difficulties of setting an exact and reproducible shot curve; however, the result underlines the major impact the shot curve has on the quality of a casting and therefore also the necessity for the founder to be careful about setting a good and reproducible shot curve.

Minimizing gas porosity

Avoiding gas porosity is one of the central tasks in designing the die casting technique. During the whole die filling process, the melt should fill the runners and gates completely to avoid the entrapment of air in the cavities. Bubbles entrapped in a casting should leave it as quickly as possible through an overflow tab. It can be anticipated that the designs of the gate geometry and overflow tabs have an essential impact on the quantity and the routes of air entering the pouring system.

Problems with gas pores were encountered in the critical area of the ring circumference during the production of an ensemble of four piston rings (Figure 8). The task of automatic optimization was to eliminate the pore risk. For this purpose, the geometries of gates

and overflow tabs were to be optimized. Taking advantage of the available symmetry, the pouring system and castings were modeled – the gates and overflow tabs were designed parametrically. **Figure 9** is a typical illustration of three variants of this geometry. For each variant, the simulation shows the distribution of air in the cavity at the end

of filling. The purpose of optimization was to keep the air entrapment in the critical area of the piston ring as low as possible. 360 variants were simulated. The result – a substantial improvement – is shown in **Figure 10**. It is possible to keep the to-be-machined area of the piston ring free of pores and consequently ensure high product quality.

Elimination of shrinkage porosity

Shrinkage porosities or cavities occur where material accumulates and normally cause problems both with respect to mechanical load of the casting and for the machining process. Material accumulations are required in most die castings for functional reasons, which makes it impossible to eliminate them completely by modification of the casting design. Consequently, it is of fundamental importance to provide the appropriate conditions for feeding. This includes the design and positioning of the gates through which the casting can be squeezed after die filling; furthermore, the solidification can be controlled to some extent by the systematic control of the temperature of the die. The present example is a cast flange of a hydraulic brake. Shrinkage cavities due to material accumulation can form in the areas of the bolt-on parts and of the lining groove. These areas will be machined and thus require to meet highest requirements of density (**Figure 11**).

Figure 12 shows the flange including casting technique. In addition to runner and gate, seven cooling circuits are available. Consequently, there are a number of degrees of freedom available for optimization. On the one hand, the gate geometry can be changed to facilitate squeezing, on the other hand, the cooling circuits can be filled with coolant in different sequences.

The reduction of shrinkage porosity was the target function in the optimization run. A total of 450 variants were simulated. **Figure 13** illustrates the improvement of solidification obtained by optimization. The methods described above cannot completely avoid shrinkage cavities, but these cavities can be reduced to a level that allows the casting to be machined without damage. In addition, this optimization run provided information on the cooling water lines that have an effect on solidification and on the ones that have not. This information is of utmost importance for

Figure 12

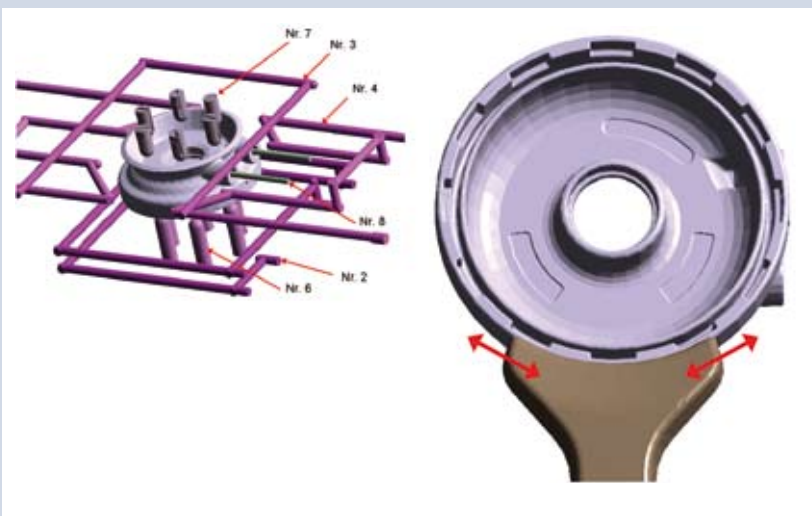

Brake flange with cooling water lines (a) and gate (b). The best possible filling of eight cooling circuits with coolant is calculated by the optimization program. The gate is parameterized and its geometry can be modified.

Figure 13

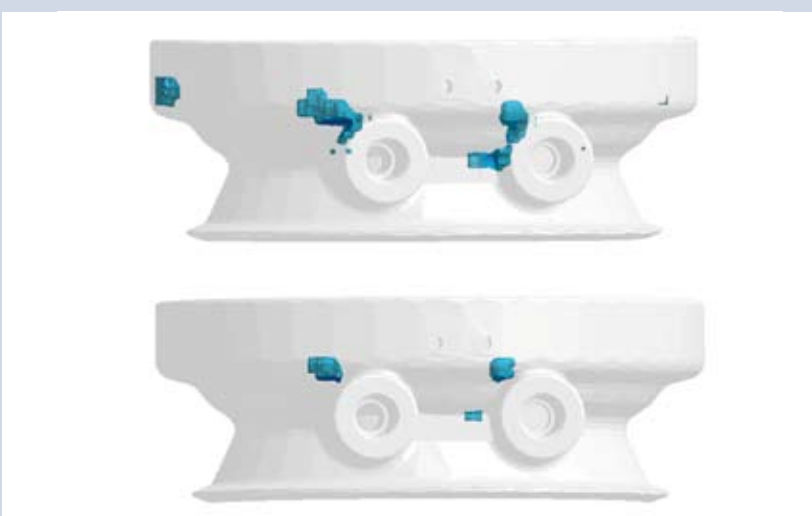

Flange with shrinkage porosity (a) before and (b) after optimization. In the optimized variant, shrinkage cavities have been eliminated in the to-be-machined areas.

the layout of a casting technique of this type. For example, it may be possible to remove cooling water lines and consequently reduce the costs of design.

Optimized squeezing

Shrinkage cavities that are surrounded by thin walls can often not be removed by squeezing. One way of

obtaining good quality in spite of this is local squeezing.

The case described below is that of dimensioning a squeezing system for the forced feeding the critical area of a casting (Figure 14). If they do not work from the beginning, such systems must be optimized by trial and error, which is expensive. The optimization program finally finds a variant that ensures optimal product quality at the critical material accumulation with minimum squeezer volume (Figure 15). It becomes clear how critical a design of this kind can be and why it is so difficult to design local squeezer systems correctly.

Summary

The examples described above illustrate that the automatic optimization of casting techniques based on simulation is also entering the casting practice. Elimination of trial and error gives the expert the opportunity to improve processes at highest quality and maximum cost effectiveness. He also learns about the sensitivities of the impacts and interactions of the process parameters to the final casting quality of process conditions. The pool of available possibilities has not been exhausted by far – it is the next generation of simulating casting processes.

Figure 14

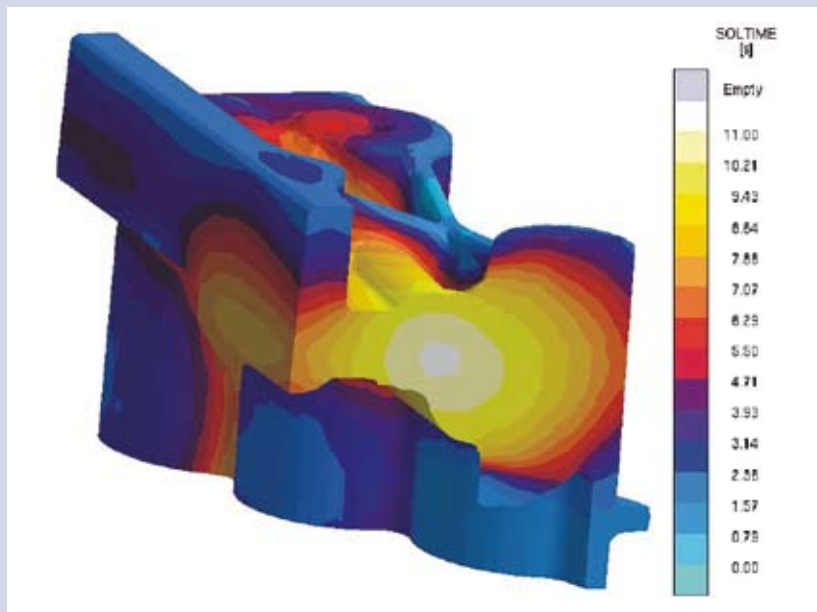

Solidification of a die casting takes longest where walls are thick. Besides, shrinkage cavities are bound to form. As this area cannot be squeezed sufficiently, local squeezing is a solution.

Figure 15

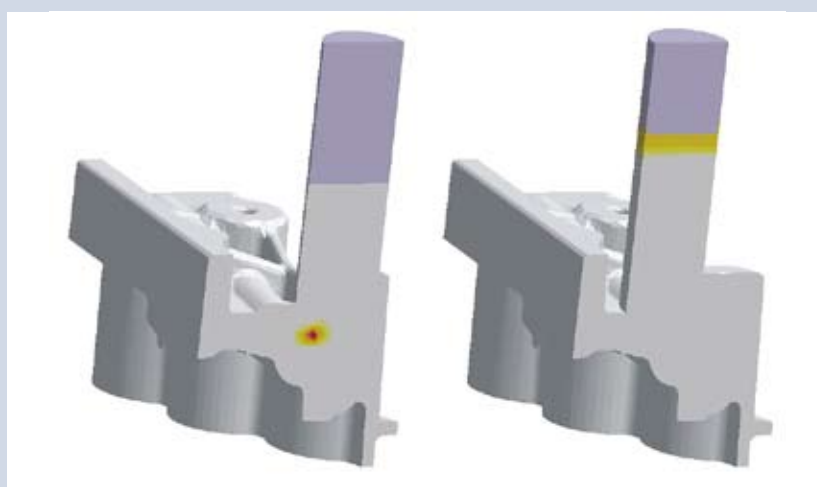

Illustration of a feeding criterion: right – design of a squeezing system found by computer optimization; no shrinkage cavities are seen in the area of inspection below the die: left – a design of very similar dimensions in which not all shrinkage cavities were avoided.

References:

- [1] Druckgusspraxis (2005) No. 3 (June), pp. 90-94.
- [2] Giesserei 91 (2004) No. 10, pp. 22-30.
- [3] Sturm, J. C.: Optimierung von Gießtechnik und Gussteilen. Symposium on Simulation in Product and Process Development, November 5-7, 2003, Bremen, Germany.
- [4] Giesserei 94 (2007) No. 4, pp. 34-42.